

DOMO PORTADAS

SISTEMA DE CORRER
LÂMINAS FIXAS E MÓVEIS

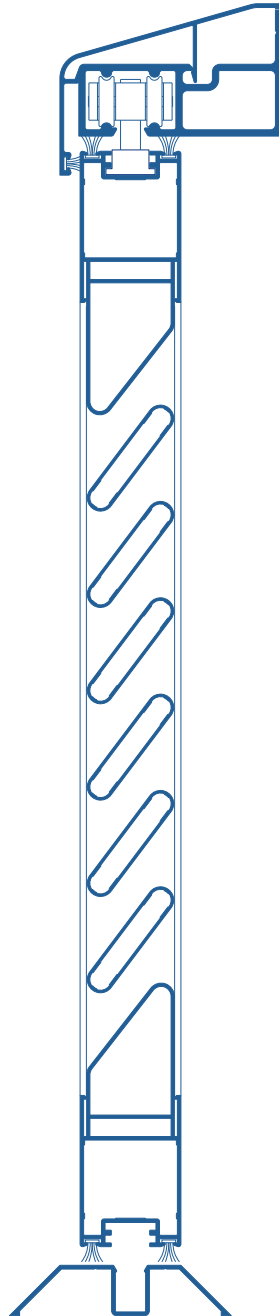

CARACTERÍSTICAS

Sistema de lâminas fixas ou móveis.
Extrusão de perfis de liga 6063.
Espessura dos perfis de 1.30 e 1.40 mm.

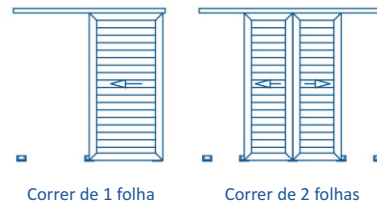

Correr de 1 folha

Correr de 2 folhas



Referência	Secção	Descrição	Stock	Inercia Ix cm ⁴	Inercia Iy cm ⁴
D-210		Lâminas fixas			
D-2048		Terminal para lâmina D-210		10.4284	4.6834
D-5070		Terminal de lâminas		0.3509	1.1773
D-5111		Folha de Portada de Correr		11.6040	8.2999
D-5334		Folha de Portada de Correr p/ bite		9.0265	16.1796
D-5336		Guia superior 48mm		12.7863	8.6499
D-5337		Inversor		0.1749	0.3154
D-5338		Tampa p/ guia superior D-5340		9.4039	19.6815
D-5340		Guia superior 82mm		10.5513	48.8575
D-5341		Tampa lateral		0.7983	9.9473
D-5342		Guia inferior 48mm		0.8546	1.8096
D-5343		Guia inferior 88mm		1.0116	11.5390



DOMO PORTADAS

SISTEMA DE CORRER
LÂMINAS FIXAS E MÓVEIS

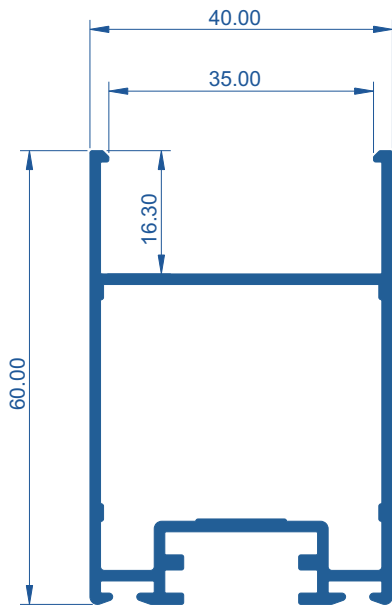

D-5111

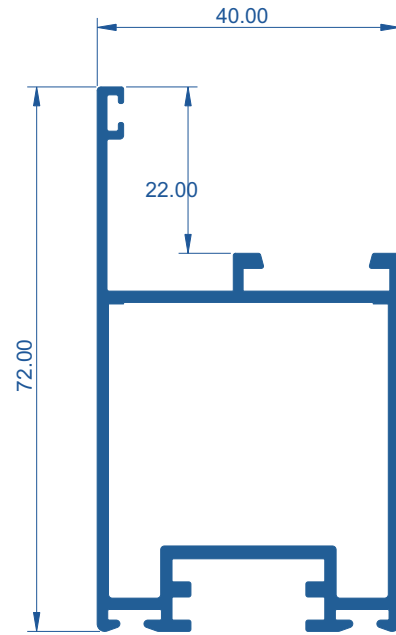

D-5334

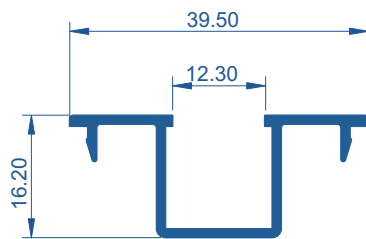

D-5070

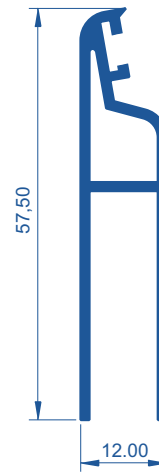

A-133

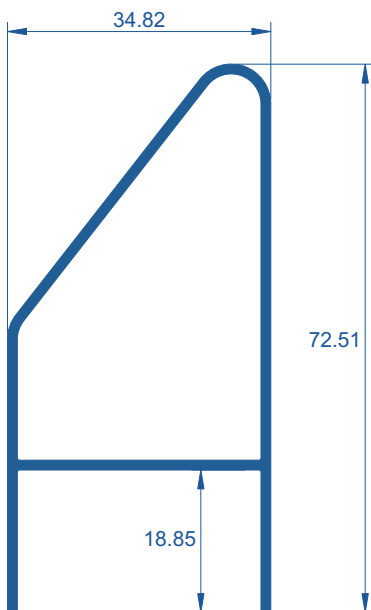

D-2048

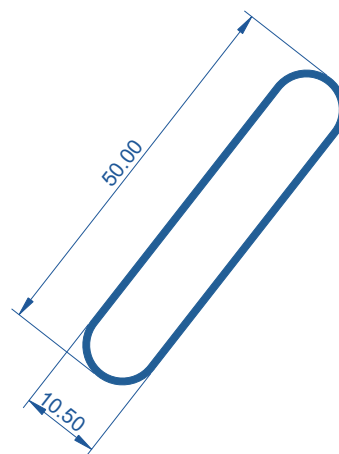

D-210

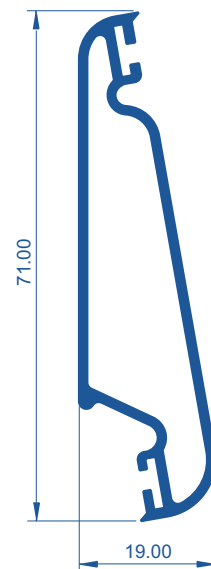

A - 132

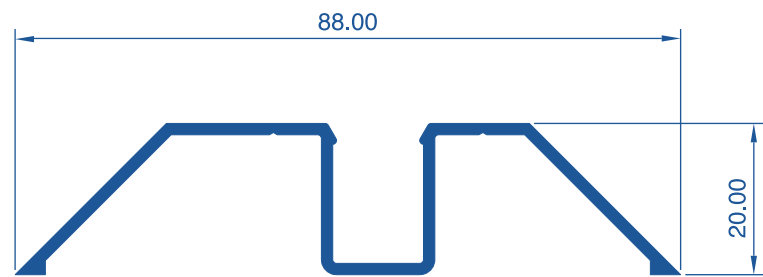
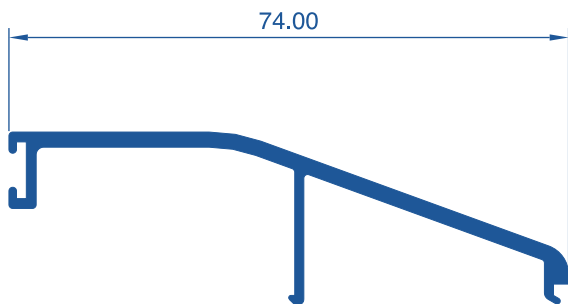
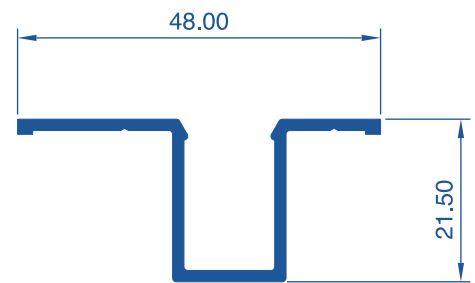
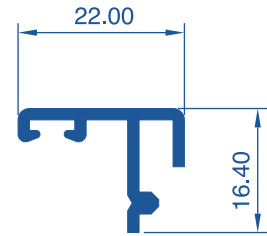
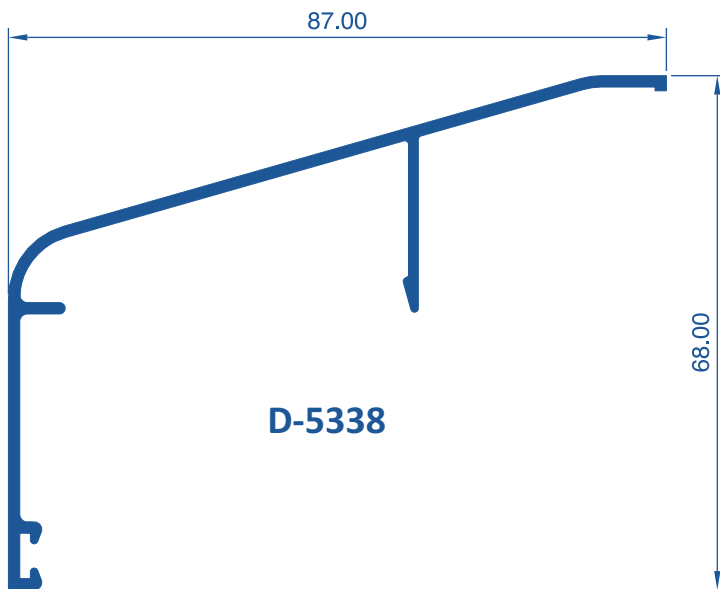

D-5341

D-5343

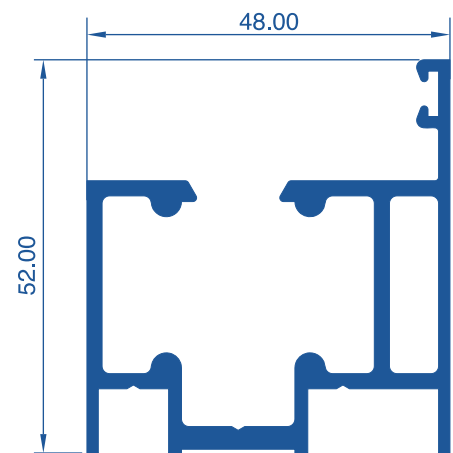
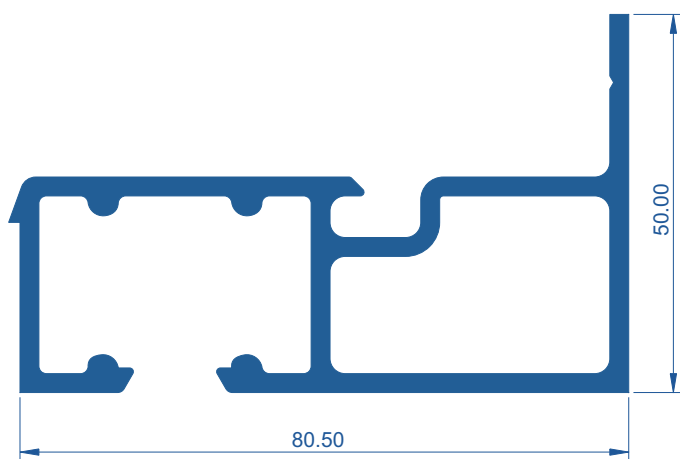

D-5340

D-5336



DOMO PORTADAS

SISTEMA DE CORRER
LÂMINAS FIXAS E MÓVEIS

Esquema de montagem

